



中国威鸿阀门有限公司
CHINA VIHUNG VALVE CO., LTD.

公司简介 Brief Introduction

中国威鸿阀门有限公司位于“中国泵阀之乡”温州市永嘉县瓯北镇安丰工业区，是集工业设计、研发、制造、销售、服务于一体大型集团型企业，专业研发制造各类球阀、蝶阀、闸阀、截止阀、旋启式止回阀、双瓣止回阀、气动执行器、电动执行器等产品，阀门可以根据国标、美标、日标、德标、ISO等标准设计制造，材料包括ASTM WCA,WCB,WCC(A105N),A217 W C1(A182 F1),A217 C5(A182 F5),A217 WC6(A182 F11),A217 WC9(A182 F22),A352 LCB(A350 LF1),A352 LCC(A350 LF2), A351 CF8(A182 F304),A351 CF8M(A182 F316), A351 CF3(A182 F304L),A351 CF3M(A182 F316L),B148 C95800,CN7M等，产品广泛应用于石油、化工、天然气管道、给排水污水处理、电站、冶金、城市供暖、医药、消防、造船等各种管道装置，先后为国家重点工程项目提供成套设备，目前客户遍布全球50多个国家和地区。

公司坚持走质量兴企之路，在质量保证方面，公司严格按照ISO 9001-2000国际质量体系认证进行管理，重金引进国内外先进生产设备和检测设备，引进三维立体模拟制造试验设计系统，3D打印技术，对产品进行优化升级，质量可靠，性能稳定，使用寿命长，采用精确机床设备，立式加工中心，高精度数控机床，确保产品零部件的高精密密度。

公司成立以来始终坚持以“质量第一、强化管理、崇尚信誉、顾客至上”为经营理念，“精益求精、力求完美”为管理方针，“以人为本，团结互信、质量上乘”为企业的生存之本，打造先进的企业文化理念，增强企业凝聚力，我们将尽心尽力为广大用户提供优质的产品，坚持打造行业领导品牌，并致力于把威鸿阀门打造成为中国领先并具有世界影响力的阀门品牌企业。



企业实力 Enterprise strength

市场竞争的基础，离不开生产实力，离不开雄厚的资金实力，离不开完善的先进的硬件设施，威鸿阀门率先引进国外先进生产设备。几年来投入巨资，对硬件设施进行更新换代，给广大用户提供高质量的工业阀门产品。



INVERTED PRESSURE BALANCE LUBRICATED PLUG VALVE ACC. TO ANSI

美标压力平衡式倒装油密封旋塞阀

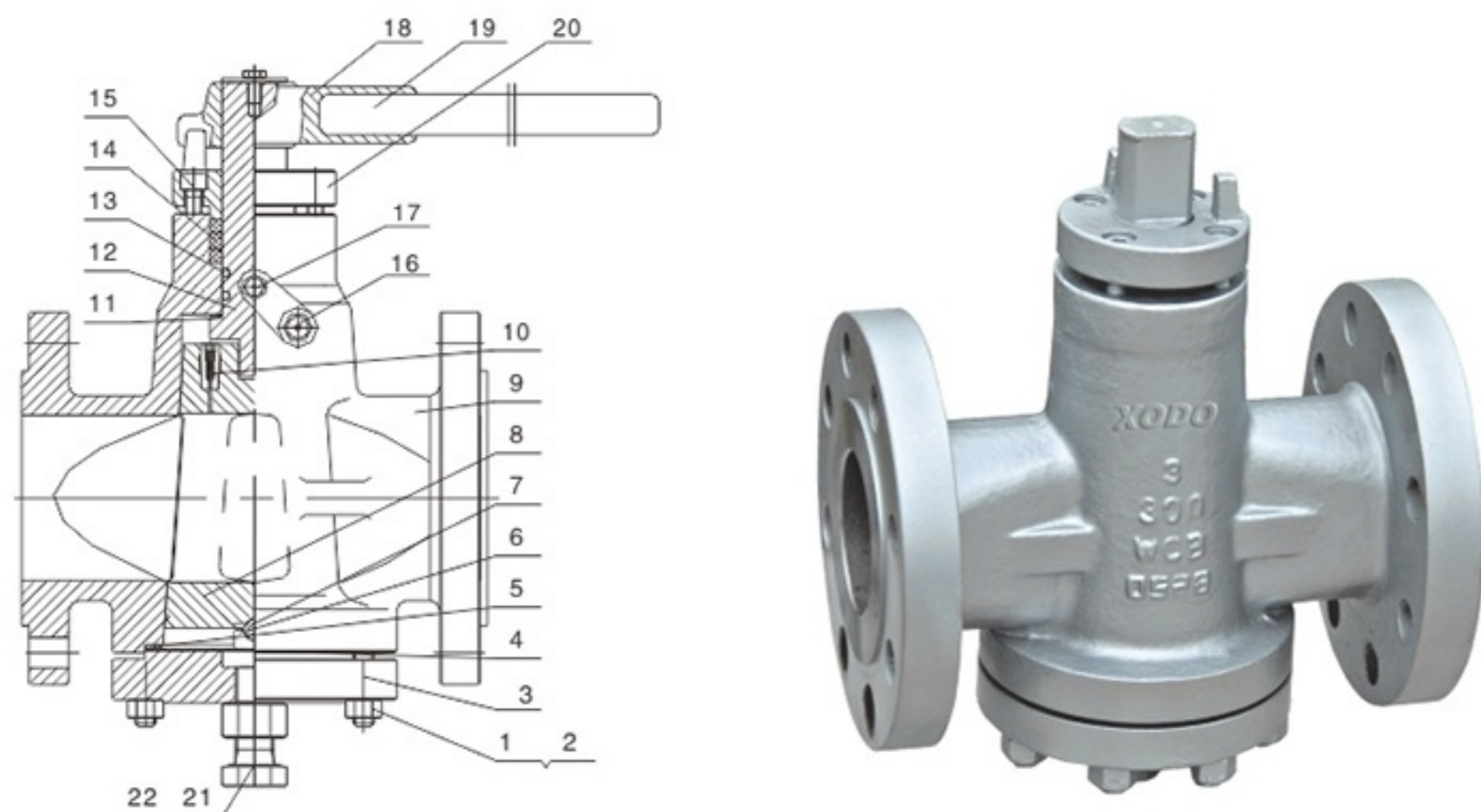

MAIN PARTS MATERIALS 主要零部件材质:

序号NO.	名称 Part name	材质 Material
1	双头螺栓 Bolt	ASTM A193-B7
2	六角螺母 Nut	ASTM A194-2H
3	阀盖 Cover	ASTM A216-WCB
4	金属隔膜 Metal diaphragm	ASTM SS304
5	缠绕垫片 Wind gasket	SS304+柔性石墨 SS304+Flexible graphite
6	球座 Ball seat	ASTM A276 410
7	球 Ball	ASTM SS304
8	旋塞 Plug	ASTM A217 CA15+氮化
9	阀体 Body	ASTM A216-WCB
10	止回阀 Check valve	组装件UCA
11	阀杆垫片 Gasket	PTFE
12	阀杆 Stem	ASTM A182 F6a
13	O型圈 "O" Ring	氟橡胶 Viton
14	填料 Packing	柔性石墨 Flexible graphite
15	螺栓 Bolt	ASTM A193-B7
16	注脂嘴 Grease nozzle	组装件UCA
17	密封紧急装置	组装件UCA
18	手柄头 Handhole	ASTM A216-WCB
19	手柄管子 Pipe	ASTM A570
20	填料压盖 Gland	ASTM A216-WCB
21	锁紧螺母 Lock nut	ASTM A194-2H
22	调整螺栓 Adjusting bolt	ASTM A193-B7

INVERTED PRESSURE BALANCE LUBRICATED PLUG VALVE ACC. TO ANSI

美标压力平衡式倒装油密封旋塞阀

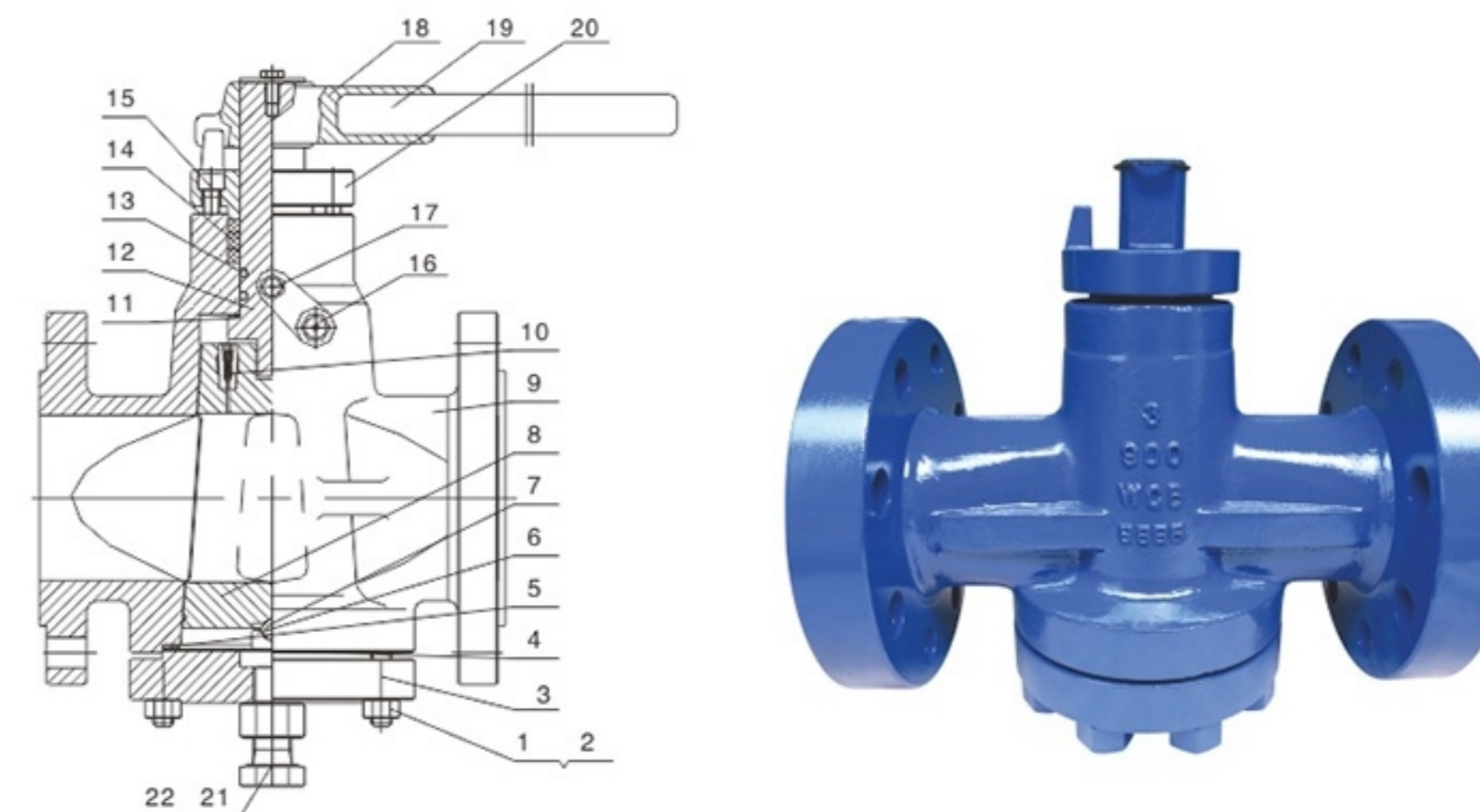

MAIN PARTS MATERIALS 主要零部件材质:

序号NO.	名称 Part name	材质 Material
1	双头螺栓 Bolt	ASTM A320-L7
2	六角螺母 Nut	ASTM A194-4
3	阀盖 Cover	ASTM A216-LCB
4	金属隔膜 Metal diaphragm	ASTM SS316
5	缠绕垫片 Wind gasket	SS316+柔性石墨 SS316+Flexible graphite
6	球座 Ball seat	ASTM A276 316
7	球 Ball	ASTM SS316
8	旋塞 Plug	ASTM A352-LCB+氮化
9	阀体 Body	ASTM A352-LCB
10	止回阀 Check valve	组装件UCA
11	阀杆垫片 Gasket	PTFE
12	阀杆 Stem	ASTM A182 F316
13	O型圈 "O" Ring	氟橡胶 Viton
14	填料 Packing	柔性石墨 Flexible graphite
15	螺栓 Bolt	ASTM A320-L7
16	注脂嘴 Grease nozzle	组装件UCA
17	密封紧急装置	组装件UCA
18	手柄头 Handhole	ASTM A216-WCB
19	手柄管子 Pipe	ASTM A570
20	填料压盖 Gland	ASTM A216-WCB
21	锁紧螺母 Lock nut	ASTM A194-4
22	调整螺栓 Adjusting bolt	ASTM A320-L7

INVERTED PRESSURE BALANCE LUBRICATED PLUG VALVE ACC. TO ANSI

美标压力平衡式倒装油密封旋塞阀

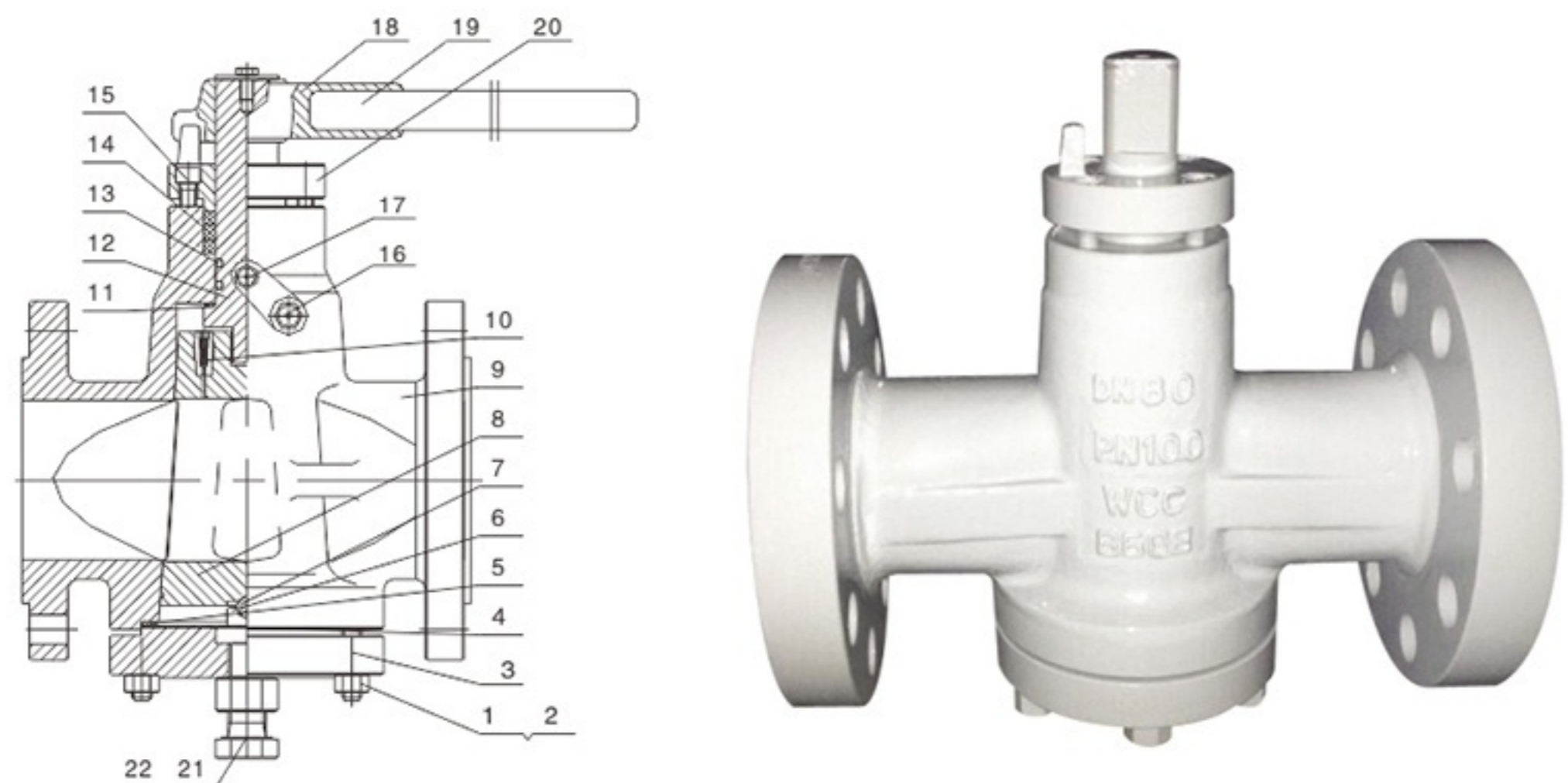

MAIN PARTS MATERIALS 主要零部件材质:

序号NO.	名称 Part name	材质 Material
1	双头螺栓 Bolt	ASTM A193-B7
2	六角螺母 Nut	ASTM A194-2H
3	阀盖 Cover	ASTM A216-WCB
4	金属隔膜 Metal diaphragm	ASTM SS304
5	缠绕垫片 Wind gasket	SS316+柔性石墨 SS316+Flexible graphite
6	球座 Ball seat	ASTM A276 316
7	球 Ball	ASTM SS316
8	旋塞 Plug	ASTM A351 CF8M+氮化
9	阀体 Body	ASTM A216-WCB
10	止回阀 Check valve	组装件UCA
11	阀杆垫片 Gasket	PTFE
12	阀杆 Stem	ASTM A182 F316
13	O型圈 "O" Ring	氟橡胶 Viton
14	填料 Packing	柔性石墨 Flexible graphite
15	螺栓 Bolt	ASTM A193-B7
16	注脂嘴 Grease nozzle	组装件UCA
17	密封紧急装置	组装件UCA
18	手柄头 Handhole	ASTM A216-WCB
19	手柄管子 Pipe	ASTM A570
20	填料压盖 Gland	ASTM A216-WCB
21	锁紧螺母 Lock nut	ASTM A194-2H
22	调整螺栓 Adjusting bolt	ASTM A193-B7

INVERTED PRESSURE BALANCE LUBRICATED PLUG VALVE ACC. TO ANSI

美标压力平衡式倒装油密封旋塞阀

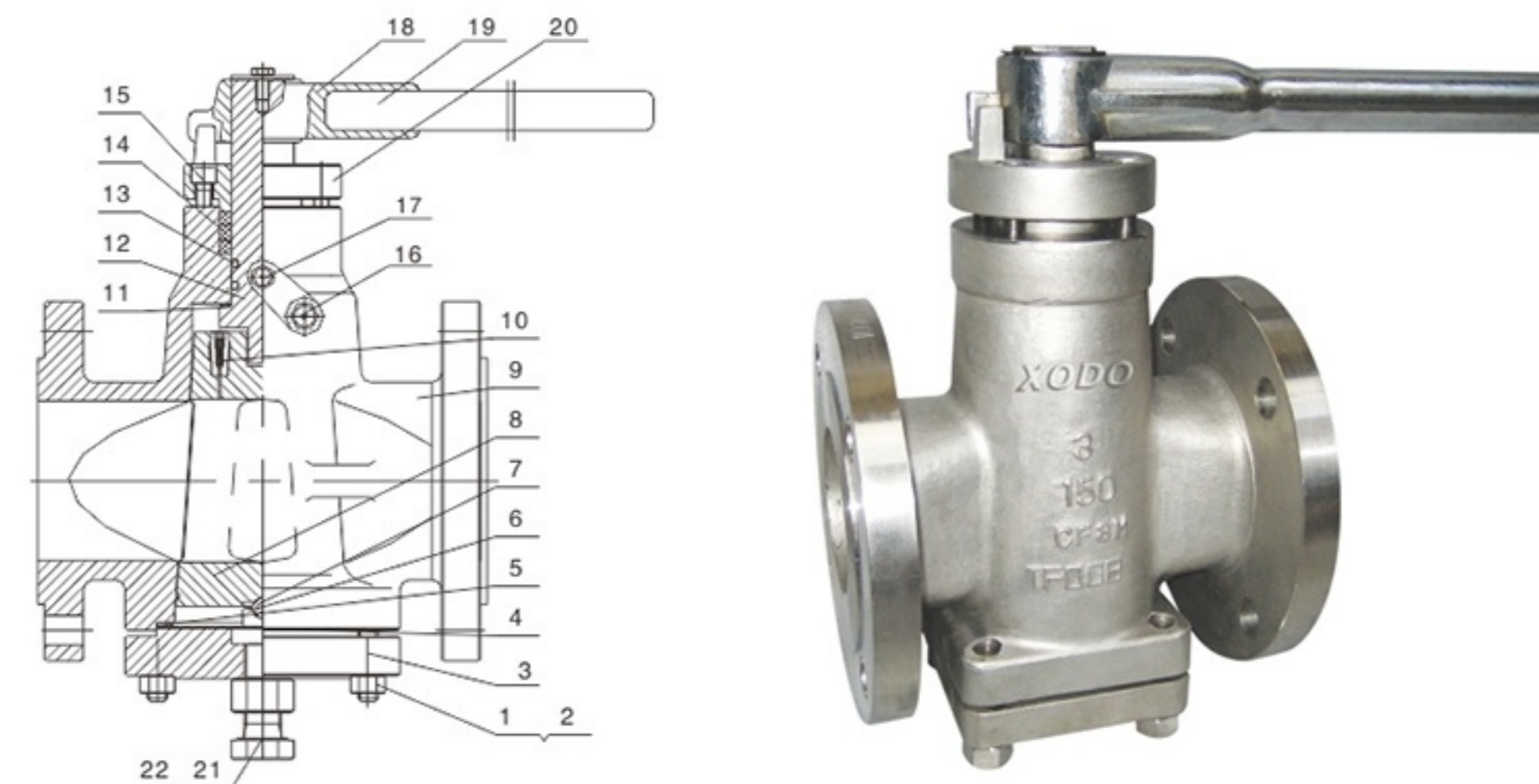

MAIN PARTS MATERIALS 主要零部件材质:

序号NO.	名称 Part name	材质 Material
1	双头螺栓 Bolt	ASTM A193-B8M
2	六角螺母 Nut	ASTM A194-8M
3	阀盖 Cover	ASTM A351-CF8M
4	金属隔膜 Metal diaphragm	ASTM SS316
5	缠绕垫片 Wind gasket	SS316+柔性石墨 SS316+Flexible graphite
6	球座 Ball seat	ASTM A276 316
7	球 Ball	ASTM SS316
8	旋塞 Plug	ASTM A351 CF8M+氮化
9	阀体 Body	ASTM A351-CF8M
10	止回阀 Check valve	组装件UCA
11	阀杆垫片 Gasket	PTFE
12	阀杆 Stem	ASTM A182 F316
13	O型圈 "O" Ring	氟橡胶 Viton
14	填料 Packing	柔性石墨 Flexible graphite
15	螺栓 Bolt	ASTM A193-B8M
16	注脂嘴 Grease nozzle	组装件UCA
17	密封紧急装置	组装件UCA
18	手柄头 Handhole	ASTM A216-WCB
19	手柄管子 Pipe	ASTM A570
20	填料压盖 Gland	ASTM A351-CF8
21	锁紧螺母 Lock nut	ASTM A194-8M
22	调整螺栓 Adjusting bolt	ASTM A193-B8M

INVERTED PRESSURE BALANCE LUBRICATED PLUG VALVE ACC. TO ANSI
美标压力平衡式倒装油密封旋塞阀

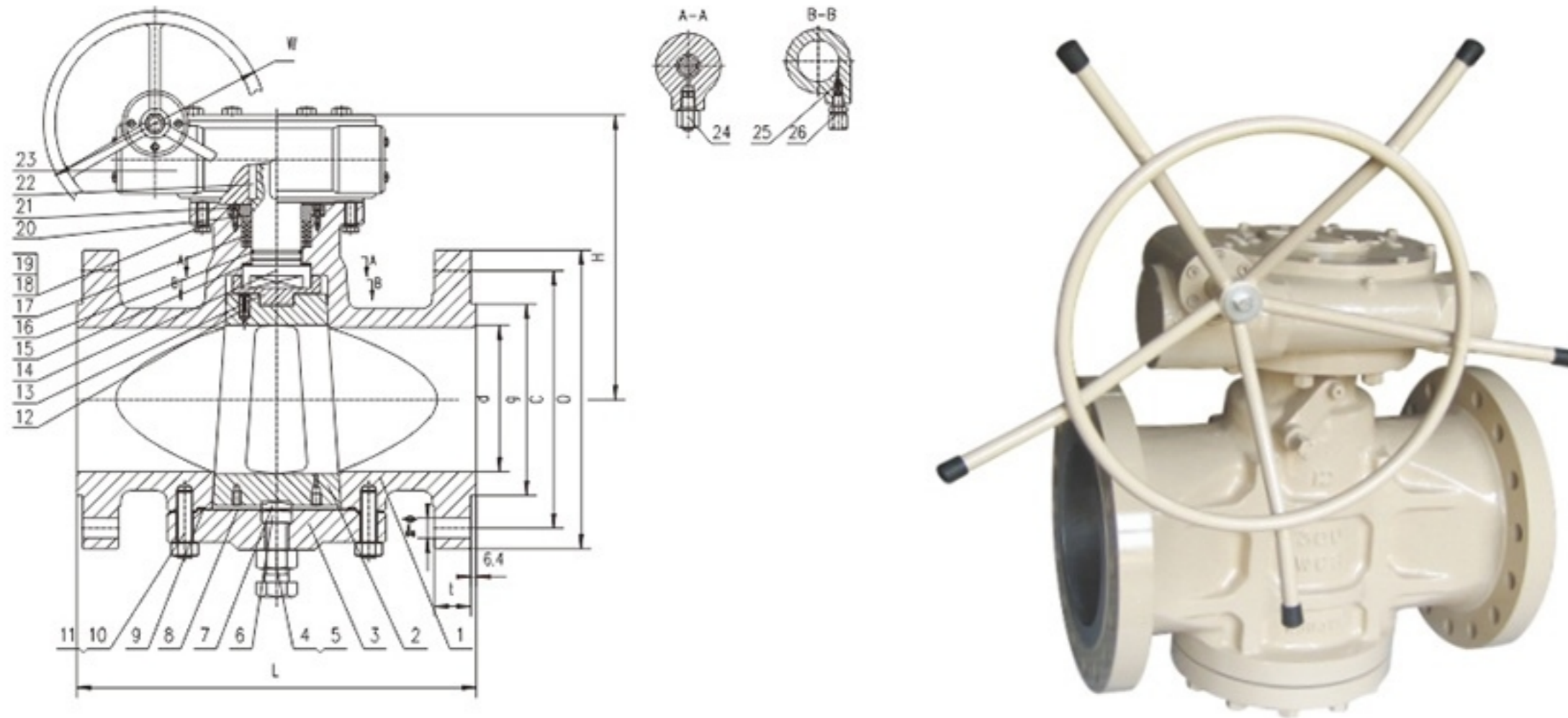

MAIN PARTS MATERIALS 主要零部件材质:

序号NO.	名称 Part name	材质 Material
1	阀体 Body	A352 LCC
2	旋塞 Plug	A352 LCC+Nitriding
3	阀盖 Cover	A352 LCC
4	螺母 Nut	A194-4
5	螺栓 Bolt	A320-L7
6	调整块 Adjustable block	A276-410
7	调整块 Adjustable block	A276-410
8	金属隔膜 Metal diaphragm	SS304
9	缠绕垫片 Wind gasket	SS304+柔性石墨 Graphite
10	螺母 Nut	A194-4
11	螺栓 Bolt	A320-L7
12	单向阀 Check Valve	组装件 UCA
13	连接器 Articulated Joint	A276-410
14	阀杆 Stem	A182-F6a
15	垫片 Gasket	PTFE
16	O型圈 O-Ring	Viton
17	填料 Packing	柔性石墨 Graphite
18	螺栓 Bolt	AISI 1035
19	弹性垫片 Spring Washer	AISI 1066
20	压盖 Gland	A352 LCC
21	螺栓 Bolt	A320-L7
22	键 Key	AISI 1045
23	涡轮驱动装置 Worm-gear Actuator	组装件 UCA
24	紧急密封装置 Emergency Device	组装件 UCA
25	单向阀 Check Valve	组装件 UCA
26	注脂阀 Grease Fitting	组装件 UCA

INVERTED PRESSURE BALANCE LUBRICATED PLUG VALVE ACC. TO ANSI
美标压力平衡式倒装油密封旋塞阀

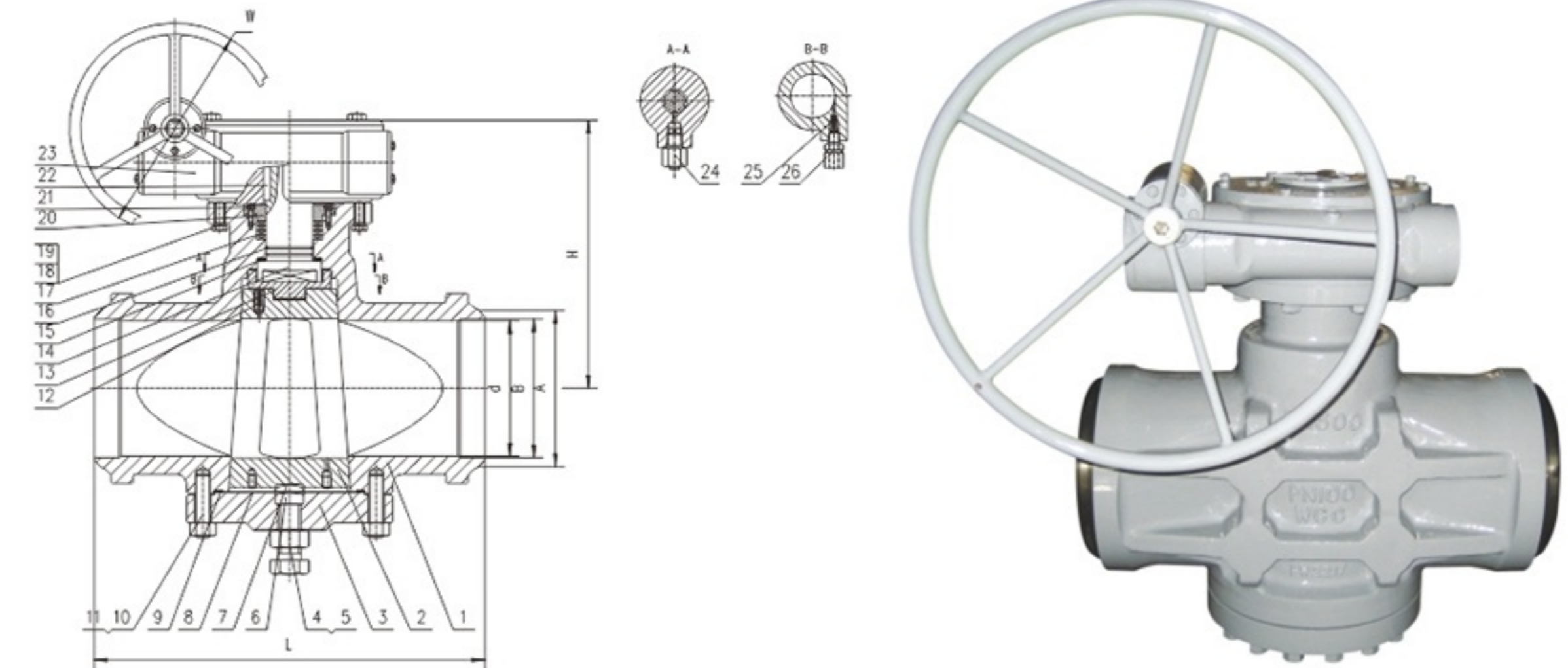

MAIN PARTS MATERIALS 主要零部件材质:

序号NO.	名称 Part name	材质 Material
1	阀体 Body	A216-WCB
2	旋塞 Plug	A216-WCB+ENP
3	阀盖 Cover	A216-WCB
4	螺母 Nut	A194-2H
5	螺栓 Bolt	A193-B7
6	调整块 Adjustable block	A276-410
7	调整块 Adjustable block	A276-410
8	金属隔膜 Metal diaphragm	SS304
9	缠绕垫片 Wind gasket	SS304+柔性石墨 Graphite
10	螺母 Nut	A194-2H
11	螺栓 Bolt	A193-B7
12	单向阀 Check Valve	组装件 UCA
13	连接器 Articulated Joint	A276-410
14	阀杆 Stem	A182-F6a
15	垫片 Gasket	PTFE
16	O型圈 O-Ring	Viton
17	填料 Packing	柔性石墨 Graphite
18	螺栓 Bolt	AISI 1035
19	弹性垫片 Spring Washer	AISI 1066
20	压盖 Gland	A216-WCB
21	螺栓 Bolt	A193-B7
22	键 Key	AISI 1045
23	涡轮驱动装置 Worm-gear Actuator	组装件 UCA
24	紧急密封装置 Emergency Device	组装件 UCA
25	单向阀 Check Valve	组装件 UCA
26	注脂阀 Grease Fitting	组装件 UCA

INVERTED PRESSURE BALANCE LUBRICATED PLUG VALVE ACC. TO ANSI

美标压力平衡式倒装油密封旋塞阀

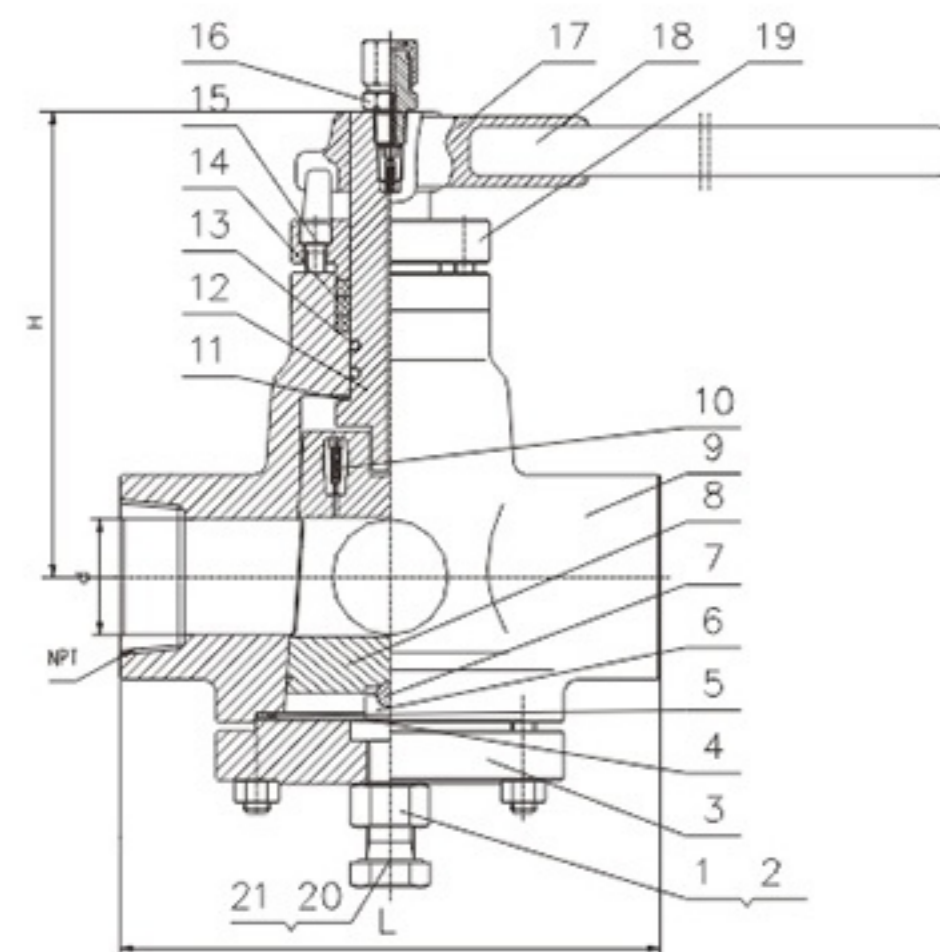

MAIN PARTS MATERIALS 主要零部件材质:

序号NO.	名称 Part name	材质 Material
1	螺栓 Bolt	A193-B7
2	螺母 Nut	A194-2H
3	阀盖 Cover	A105
4	金属隔膜 Metal diaphragm	SS304
5	缠绕垫片 Wind gasket	SS304+Graphite 柔性石墨
6	调整块 Adjustable block	A276-410
7	球 Ball	SS304
8	旋塞 Plug	A182-F6a+Nitriding
9	阀体 Body	A105
10	单向阀 Check Valve	组装件 UCA
11	垫片 Gasket	PTFE
12	阀杆 Stem	A182-F6a
13	O型圈 O-Ring	Viton
14	填料 Packing	Graphite 柔性石墨
15	螺栓 Bolt	A193-B7
16	注脂阀 Grease Fitting	组装件 UCA
17	管子 Pipe	A570
18	手柄 Handhold	A216-WCB
19	压盖 Gland	A216-WCB
20	螺栓 Bolt	A193-B7
21	螺母 Nut	A194-2H

INVERTED PRESSURE BALANCE LUBRICATED PLUG VALVE ACC. TO ANSI

美标压力平衡式倒装油密封旋塞阀

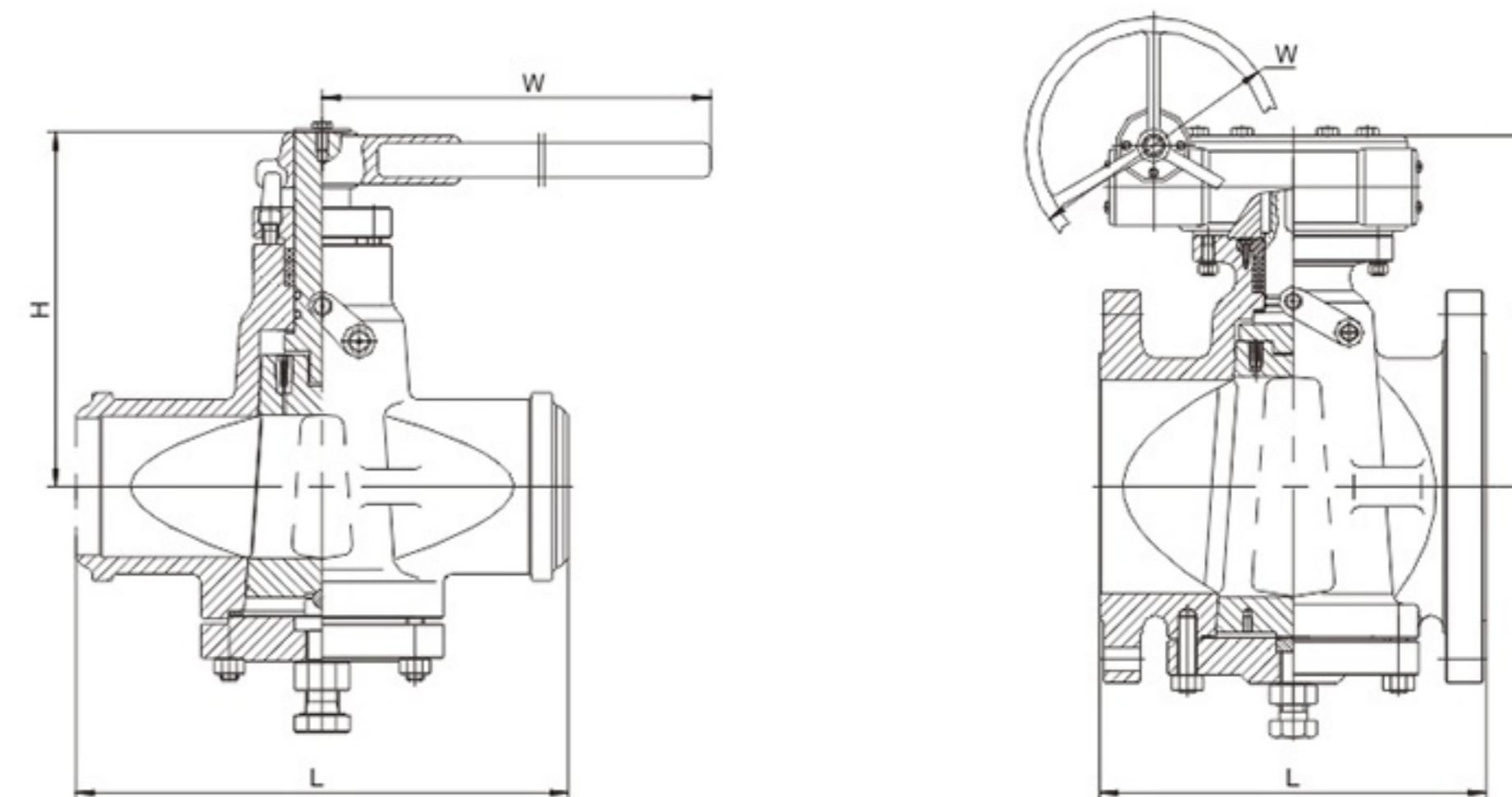

型号 Model		X47W/X347W-150LB														
口径 Size	mm	15	20	25	32	40	50	65	80	100	125	150	200	250	300	350
	in	1/2	3/4	1	1 1/4	1 1/2	2	2 1/2	3	4	5	6	8	10	12	14
L		108	117	127	140	165	178	190	203	229	254	267	292	330	356	381
H		180	180	185	200	214	215	250	270	300	340	365	400	450	510	590
W		400	400	500	500	600	600	820	820	300	300	320	320	350	380	380
重量(Kg)Weight		10	12	14	17	19	21	29	33	48	75	98	125	171	230	370
型号 Model		X47W/X347W-300LB														
口径 Size	mm	15	20	25	32	40	50	65	80	100	125	150	200	250	300	350
	in	1/2	3/4	1	1 1/4	1 1/2	2	2 1/2	3	4	5	6	8	10	12	14
L		140	152	165	178	190	216	241	283	305	381	403	419	457	502	762
H		180	180	185	200	210	215	250	270	300	340	365	400	450	510	590
W		400	400	500	600	600	820	1000	1000	300	300	320	320	350	380	380
重量(Kg)Weight		12	14	16	19	21	24	31	36	61	86	130	190	255	380	560
型号 Model		X47W/X347W-600LB														
口径 Size	mm	15	20	25	32	40	50	65	80	100	125	150	200	250	300	350
	in	1/2	3/4	1	1 1/4	1 1/2	2	2 1/2	3	4	5	6	8	10	12	14
L		165	190	216	229	241	292	330	356	432	508	559	660	787	838	889
H		180	180	185	200	210	215	250	270	300	340	365	400	450	510	590
W		400	400	500	500	600	600	820	820	300	300	320	320	350	380	380
重量(Kg)Weight		14	16	18	20	24	29	35	47	91	129	210	320	660	920	1250
型号 Model		X47W/X347W-900LB														
口径 Size	mm	15	20	25	32	40	50	65	80	100	125	150	200	250	300	350
	in	1/2	3/4	1	1 1/4	1 1/2	2	2 1/2	3	4	5	6	8	10	12	14
L		216	229	254	279	305	368	419	381	457	559	610	737	838	965	1029
H		180	180	185	200	210	215	250	270	300	340	365	400	450	510	590
W		400	400	500	600	600	820	1000	1000	300	300	320	320	350	380	380
重量(Kg)Weight		17	29	21	24	30	37	44	65	110	160	255	380	810	1050	1460

FLANGE-CONNECTION LIFTING PLUG VALVE ACC. TO ANSI

法兰连接美标提升式硬密封旋塞阀

PRODUCT STRUCTURAL FEATURES 产品结构特点:

Flange-connection lifting plug valve acc. to ANSI is applicable to the cutting and connection of pipelines medium that are used in various industries such as petroleum, chemical industry, pharmacy, chemical fertilizer, power industry etc under nominal pressure of CLASS150~1500LBS, and working temperature of -29~550°C.

法兰连接美标提升式硬密封旋塞阀适用于公称压力CLASS150~1500LBS, 工作温度-29~550°C的石油、化工、制药、化肥、电力行业等各种工况的管路上, 切断或接通管路介质。

MAIN STRUCTURAL FEATURES 其主要结构特点:

- 1、The product has reasonable structure, reliable sealing, excellent performance and beautiful appearance.
- 2、Opening and closing of the valve is carried out while the sealed surface is taken off, so it will not cause abrasion on the sealed surface.
- 3、Its characteristic double-direction flow makes installation and use more convenient.
- 4、The materials of the parts and sizes of flanges can be reasonably configured according to the actual operation condition of the requirements of the customers, so as to meet the various needs of engineering.

- 1、产品结构合理、密封可靠、性能优良、造型美观。
- 2、阀门的启闭过程是在密封面脱离的状态下进行的, 不会造成密封面的磨损。
- 3、双向流动, 安装使用更方便。
- 4、零件材质及法兰尺寸可根据实际工况或用户要求合理选配, 满足各种工程需要。

PRINCIPLE OF OPENING AND CLOSING OF THE VALVE 阀门的启闭工作原理

Process of opening and closing of the valve. when opening the valve, first of all, turn the hand wheel to make the plug lifted and separated with the sealed surface, then turn the handle by 90 degree to connect the channel of plug to the channel of valve body, so that the valve is opened; when closing the valve, first of all, turn the handle by 90 degree to make the channel of plug vertical to the channel of valve body, and then turn the hand wheel to descend the plug, so that the valve is closed.

阀门的启闭过程: 开启阀门时, 要先旋转手轮, 使塞子上升, 与密封面脱离, 再旋转手柄90°, 使塞子的通道和阀体的通道相通, 达到开启的目的。而关闭的过程是先旋转手柄90°, 使塞子的通道和阀体的通道垂直, 再旋转手轮, 使塞子下降, 连接密封。

TECHNICAL SPECIFICATION 技术规范:

结构形式 Structural formation	BC
驱动方式 Driving manner	BB-BG-QS&Y 手柄、伞齿轮、手柄 Hand wheel、bevel gear、wrench
设计标准 Design standard	API 599、API 6D
结构长度 Face to face	ASME B16.10
连接法兰 Flange ends	ASME B16.5
试验和检验 Test & inspection	API 598、API 6D

※注: 阀门的连接法兰尺寸可根据用户要求设计制造。
Note: the size of serial valve connecting flange can be designed according to customers' requirement.

PRODUCTS PERFORMANCE SPECIFICATION 产品性能规范:

公称压力(LB) Nominal pressure	壳体试验压力(MPa) Shell test	密封试验压力(MPa) Sealing test	适用温度(°C) Suitable temp.	适用介质 Suitable medium
150	3.0	2.2	≤300°C/350°C	水、蒸汽、油品等 Water oil & gas
300	7.5	5.5		
600	15.0	11.0		
900	22.5	16.5		
1500	37.5	27.5		
2500	63.0	46.2		

FLANGE-CONNECTION LIFTING PLUG VALVE ACC. TO ANSI

法兰连接美标提升式硬密封旋塞阀

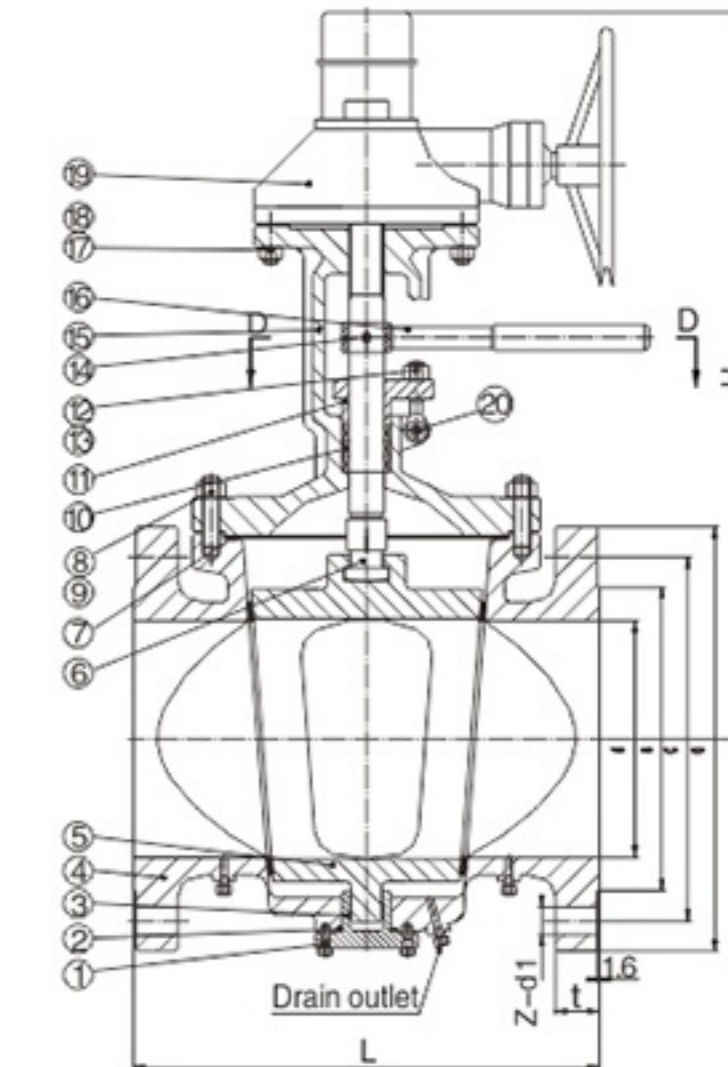

MAIN PARTS MATERIALS 主要零部件材质:

序号NO.	名称 Part name	材质 Material
1	螺栓 Bolt	A193 B16
2	垫片 Gasket	SS304+石墨 Graphite
3	底盖 Under plate	A217 C5
4	阀体 Body	A217 C5
5	旋塞 Plug	A217 C5+氮化 Nitriding
6	阀杆 Stem	A276 410
7	垫片 Gasket	SS304+石墨 Graphite
8	螺栓 Bolt	A193 B16
9	螺母 Nut	A194 7
10	填料 Packing	柔性石墨 Flexible Graphite
11	压盖 Gland	A217 C5
12	螺栓 Bolt	A193 B16
13	螺母 Nut	A194 7
14	销 Key	SS304
15	阀盖 Cover	A217 C5
16	手柄 Handle	A570
17	螺栓 Bolt	A193 B16
18	螺母 Nut	A194 7
19	齿轮 Gear	UCA
20	销 Key	SS304

FLANGE-CONNECTION LIFTING PLUG VALVE ACC. TO ANSI

法兰连接美标提升式硬密封旋塞阀

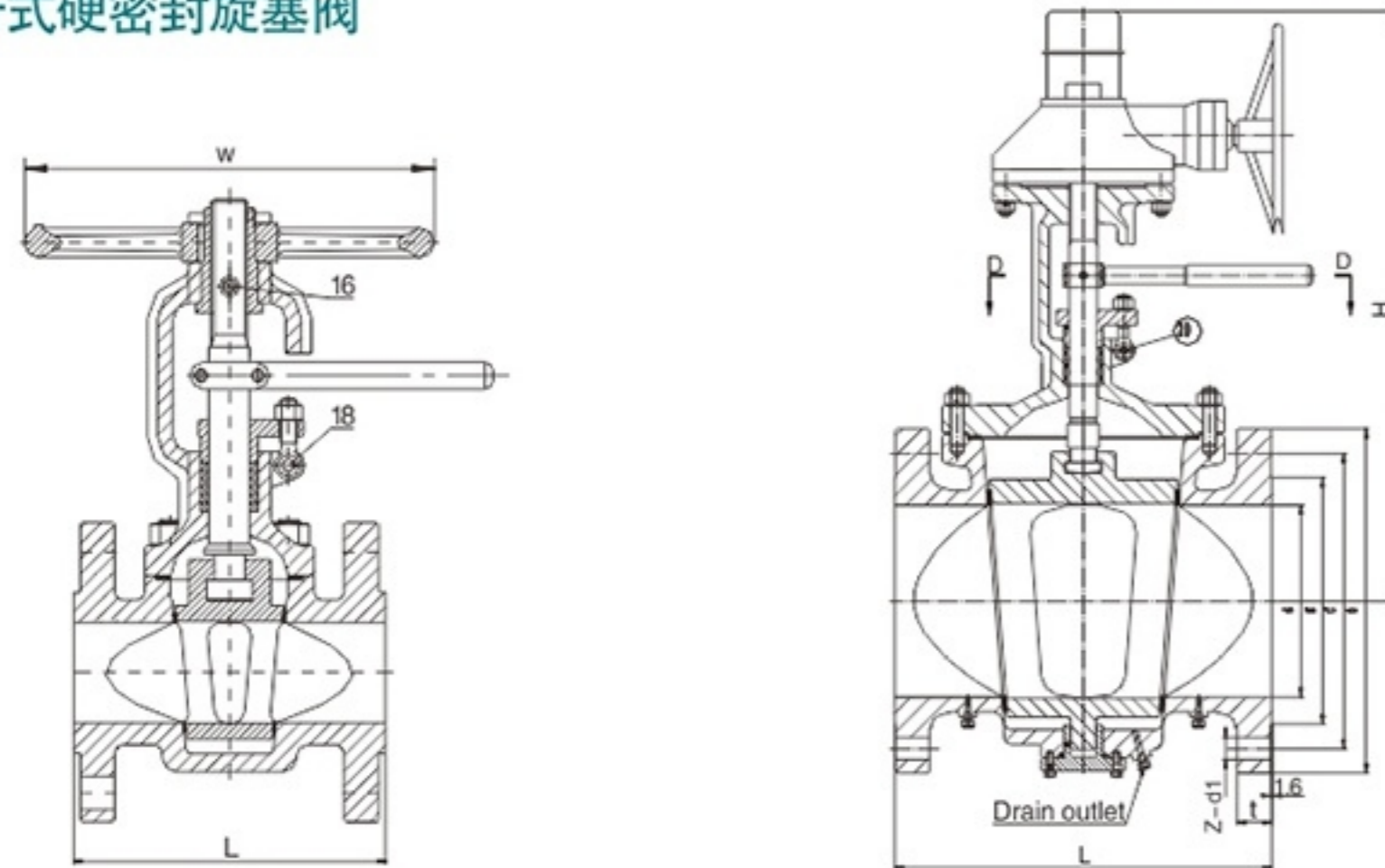

型号 Model		TSX543W/TSX43W-150LB														
口径 Size	mm	15	20	25	32	40	50	65	80	100	125	150	200	250	300	350
	in	1/2	3/4	1	1 1/4	1 1/2	2	2 1/2	3	4	5	6	8	10	12	14
L		108	117	127	140	165	178	190	203	229	254	267	292	330	356	381
H		190	195	225	260	280	310	250	395	300	470	535	590	630	680	720
W		280	280	280	300	300	300	820	300	300	340	400	450	450	500	500
重量(Kg)Weight		9	10	11	17	19	23	29	32	48	82	98	130	178	250	380
型号 Model		TSX543W/TSX43W-300LB														
口径 Size	mm	15	20	25	32	40	50	65	80	100	125	150	200	250	300	350
	in	1/2	3/4	1	1 1/4	1 1/2	2	2 1/2	3	4	5	6	8	10	12	14
L		140	152	165	178	190	216	241	283	305	381	403	419	457	502	762
H		190	195	225	260	280	310	340	395	435	470	535	590	630	680	720
W		280	280	280	300	300	300	300	300	300	340	400	450	450	500	500
重量(Kg)Weight		10	12	14	19	21	28	34	39	75	95	135	200	255	415	650
型号 Model		TSX543W/TSX43W-600LB														
口径 Size	mm	15	20	25	32	40	50	65	80	100	125	150	200	250	300	350
	in	1/2	3/4	1	1 1/4	1 1/2	2	2 1/2	3	4	5	6	8	10	12	14
L		165	190	216	229	241	292	330	356	432	508	559	660	787	838	889
H		190	195	225	260	280	310	340	395	435	470	535	590	630	680	720
W		280	280	280	300	300	300	300	300	300	340	400	450	450	500	500
重量(Kg)Weight		13	14	19	23	25	32	40	55	105	139	300	440	730	1150	1570
型号 Model		TSX543W/TSX43W-900LB														
口径 Size	mm	15	20	25	32	40	50	65	80	100	125	150	200	250	300	350
	in	1/2	3/4	1	1 1/4	1 1/2	2	2 1/2	3	4	5	6	8	10	12	14
L		216	229	254	279	305	368	419	381	457	559	610	737	838	965	1029
H		190	195	225	260	280	310	340	395	435	470	535	590	630	680	720
W		280	280	280	300	300	300	300	300	300	340	400	450	450	500	500
重量(Kg)Weight		16	17	26	30	33	39	50	70	137	181	397	590	860	1470	1880

INTEGRAL STEEL PIPE FLANGE JB/T 79.1-1994

整体钢制管法兰JB/T 79.1-1994

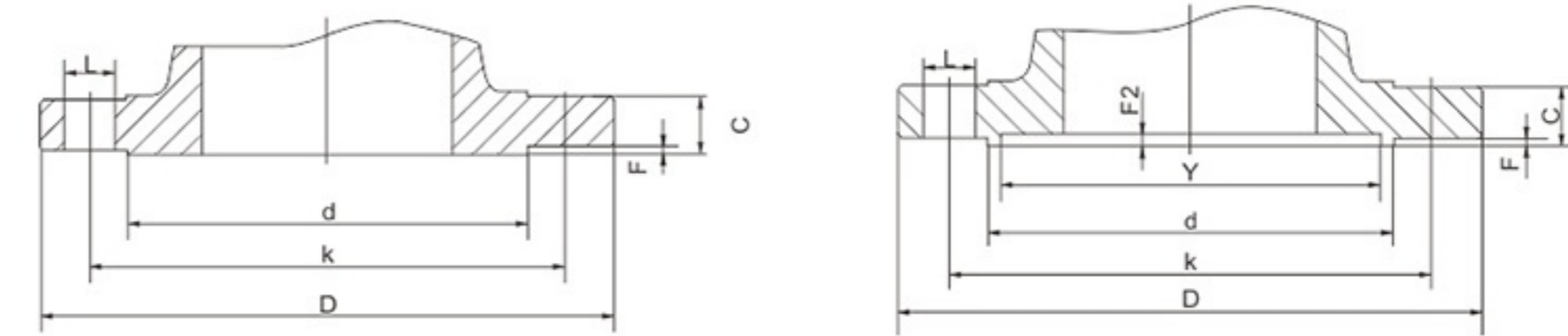

PN1.6~2.5MPa RF

PN4.0~10MPa FM

PN1.6MPa RF

DN	D	k	L	螺栓n-Th	d	f	C
15	95	65	14	4-M12	45	2	14
20	105	75	14	4-M12	55	2	14
25	115	85	14	4-M12	65	2	14
32	140	100	18	4-M16	78	2	16
40	150	110	18	4-M16	85	3	16
50	165	125	18	4-M16	100	3	16
65	185	145	18	4-M16	120	3	18
80	200	160	18	8-M16	135	3	20
100	220	180	18	8-M16	155	3	20
125	250	210	18	8-M16	185	3	22
150	285	240	23	8-M20	210	3	24
200	340	295	23	12-M20	265	3	26
250	405	355	26	12-M24	320	3	30
300	460	410	26	12-M24	375	4	30
350	520	470	26	16-M24	435	4	34
400	580	525	30	16-M27	485	4	36
450	640	585	30	20-M27	545	4	40
500	715	650	34	20-M30	608	4	44
600	840	770	36	20-M33	718	5	48
700	910	840	36	24-M33	788	5	50
800	1025	950	41	24-M36	898	5	52

PN2.5MPa RF

DN	D	k	L	螺栓n-Th	d	f	C
15	95	65	14	4-M12	45	2	16
20	105	75	14	4-M12	55	2	16
25	115	85	14	4-M12	65	2	16
32	140	100	18	4-M16	78	2	18
40	150	110	18	4-M16	85	3	18
50	165	125	18	4-M16	100	3	20
65	185	145	18	8-M16	120	3	22
80	200	160	18	8-M16	135	3	22
100	230	190	23	8-M20	160	3	24
125	270	220	26	8-M24	188	3	28
150	300	250	26	8-M24	218	3	30
200	360	310	26	12-M24	278	3	34
250	425	370	30	12-M27	332	3	36
300	485	430	30	16-M27	390	4	40
350	555	490	34	16-M30	448	4	44
400	620	550	36	16-M33	505	4	48
450	670	600	36	20-M33	555	4	50
500	730	660	36	20-M33	610	4	52
600	845	770	41	20-M36	718	5	56
700	960	875	42	24-M39	815	5	60
800	1085	990	48	24-M45	930	5	64

INTEGRAL STEEL PIPE FLANGE JB/T 79.2-1994

整体钢制管法兰JB/T 79.2-1994

PN4.0MPa FM

DN	D	k	L	螺栓n-Th	d	Y	f	f2	C
15	95	65	14	4-M12	45	40	2	4	16
20	105	75	14	4-M12	55	51	2	4	16
25	115	85	14	4-M12	65	58	2	4	16
32	140	100	18	4-M16	78	66	2	4	18
40	150	110	18	4-M16	85	76	3	4	18
50	165	125	18	4-M16	100	88	3	4	20
65	185	145	18	8-M16	120	110	3	4	22
80	200	160	18	8-M16	135	121	3	4	22
100	235	190	23	8-M20	160	150	3	4.5	24
125	270	220	26	8-M24	188	176	3	4.5	28
150	300	250	26	8-M24	218	204	3	4.5	30
200	375	320	30	12-M27	282	260	3	4.5	38
250	450	385	34	12-M30	345	313	3	4.5	42
300	515	450	34	16-M30	408	364	4	4.5	46
350	580	510	36	16-M33	465	422	4	5	52
400	660	585	41	16-M36	535	474	4	5	58
450	685	610	41	20-M36	560	524	4	5	60
500	755	670	42	20-M39	612	576	4	5	62
600	890	795	48	20-M45	730	678	5	6	62
700	995	900	48	24-M45	835	768	5	6	68

PN6.4MPa FM

DN	D	k	L	螺栓n-Th	d	Y	f	f2	C
15	105	75	14	4-M12	55	40	2	4	18
20	130	90	18	4-M16	68	51	2	4	20
25	140	100	18	4-M16	78	58	2	4	22
32	155	110	23	4-M20	82	66	2	4	24
40	170	125	23	4-M20	95	76	3	4	24
50	180	135	23	4-M20	105	88	3	4	26
65	205	160	23	8-M20	130	110	3	4	28
80	215	170	23	8-M20	140	121	3	4	30
100	250	200	26	8-M24	168	150	3	4.5	32
125	295	240	30	8-M27	202	176	3	4.5	36
150	345	280	34	8-M30	240	204	3	4.5	38
200	405	345	36	12-M33	300	260	3	4.5	44
250	470	400	36	12-M33	352	313	3	4.5	48
300	530	460	36	16-M33	412	364	4	4.5	54
350	600	525	41	16-M36	475	422	4	5	60
400	670	585	42	16-M39	525	474	4	5	66
500	800	705	48	20-M45	640	576	4	5	70
600	930	820	58	20-M52	750	678	5	6	76

PN10.0MPa FM

DN	D	k	L	螺栓n-Th	d	Y	f	f2	C
50	195	145	26	4-M24	112	88	3	4	28
65	220	170	26	8-M24	138	110	3	4	32
80	230	180	26	8-M24	148	121	3	4	34
100	265	210	30	8-M27	172	150	3	4.5	38
125	315	250	34	8-M30	210	176	3	4.5	42
150	355	290	34	12-M30	250	204	3	4.5	46
200	430	360	36	12-M33	312	260	3	4.5	54
250	505	430	41	12-M36	382	313	3	4.5	60
300	585	500	42	16-M39	442	364	4	4.5	70
350	655	560	48	16-M45	498	422	4	5	76
400	715	620	48	16-M45	558	474	4	5	80

INTEGRAL STEEL PIPE FLANGE JIS B2212-B2214-1999

整体钢制管法兰JIS B2212-B2214-1999

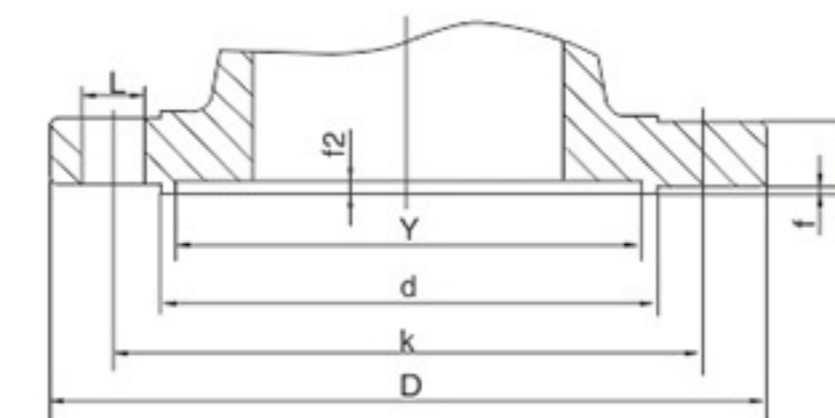

PN16.0MPa

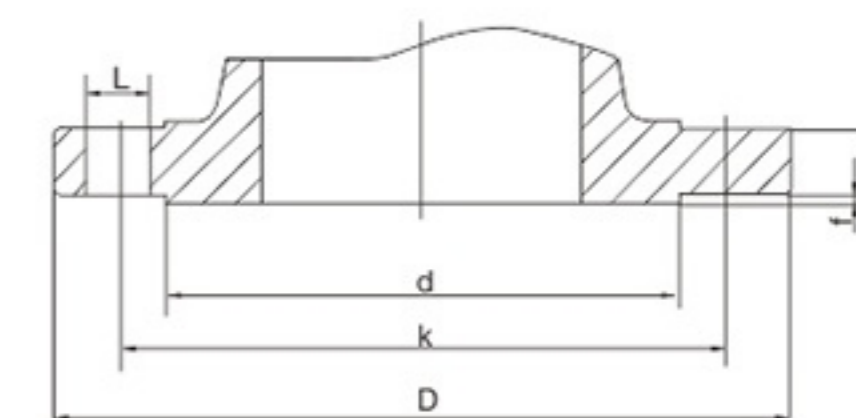

JIS10K-20KRF

PN16.0MPa FM

DN	D	k	L	螺栓n-Th	d	Y	f	f2	C
25	140	100	23	4-M20	72	58	2	4	28
32	165	115	25	4-M22	85	66	2	4	30
40	175	125	27	4-M24	92	76	3	4	32
50	215	165	25	8-M22	132	88	3	4	36
65	245	190	30	8-M27	152	110	3	4	44
80	260	205	30	8-M27	168	121	3	4	46
100	300	240	34	8-M30	200	150	3	4.5	48
150	390	318	41	12-M36	270	204	3	4.5	66
200	480	400	48	12-M42	345	260	3	4.5	78
250	580	485	54	12-M48	425	313	3	4.5	88
300	665	570	54	16-M48	510	364	4	4.5	100

JIS 10K RF

DN	D	k	L	螺栓n-Th	d	f	C
100	210	175	19	8-M16	155	2	18
125	250	210	23	8-M20	185	2	20
150	280	240	23	8-M20	215	2	22
200	330	290	23	12-M20	265	2	22
250	400	355	25	12-M22	325	2	24
300	445	400	25	16-M22	370	3	24
350	490	445	25	16-M22	415	3	26
400	560	510	27	16-M24	475	3	28
450	620	565	27	20-M24	530	3	30
500	675	620	27	20-M24	585	3	30

JIS 20K RF

DN	D	k	L	螺栓n-Th	d	f	C
100	225	182	23	8-M20	160	2	24
125	270	225	25	8-M22	195	2	26
150	305	260	25	12-M22	230	2	28
200	350	305	25	12-M22	275	2	30
250	430	380	27	12-M24	345	2	34
300	480	430	27	16-M24	395	3	35
350	540	480	33	16-M30 x 3	440	3	40
400	605	540	33	16-M30 x 3	495	3	46
450	675	605	33	20-M30 x 3	560	3	48
500	730	660	33	20-M30 x 3	615	3	50

INTEGRAL STEEL PIPE FLANGE ASME/ANSI B16.5A-1992 B 16.47-1996

整体钢制管法兰ASME/ANSI B16.5A-1992 B 16.47-1996

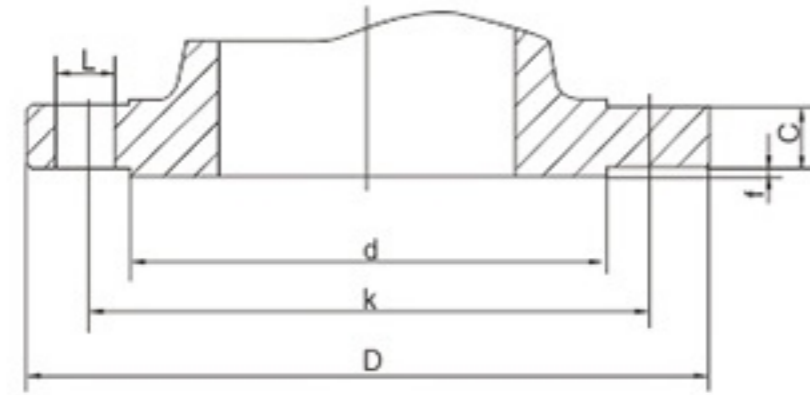

CLASS150 RF

DN	NPS	D	k	L	螺栓n-Th	d	f	C
25	1	108	79.5	15	4-M14	51	1.6	12
40	1 1/2	127	98.5	15	4-M14	73	1.6	15
50	2	152	120.5	19	4-M16	92	1.6	16
65	2 1/2	178	139.5	19	4-M16	105	1.6	18
80	3	190	152.5	19	4-M16	127	1.6	19
100	4	229	190.5	19	8-M16	157	1.6	24
125	5	254	216	22	8-M20	186	1.6	24
150	6	279	241.5	22	8-M20	216	1.6	26
200	8	343	298.5	22	8-M20	270	1.6	29
250	10	406	362	25	12-M24	324	1.6	31
300	12	483	432	25	12-M24	381	1.6	32
350	14	533	476	29	12-M27	413	1.6	35
400	16	597	540	29	16-M27	470	1.6	37
450	18	635	578	32	16-M30	533	1.6	40
500	20	699	635	32	20-M30	584	1.6	43
600	24	813	749.5	35	20-M33	692	1.6	48
700	28	927	863.5	35	28-M33	800	1.6	72
800	32	1060	978	41	28-M39	914	1.6	81

CLASS300 RF

DN	NPS	D	k	L	螺栓n-Th	d	f	C
25	1	124	89	19	4-M16	51	1.6	18
40	1 1/2	156	114.5	22	4-M20	73	1.6	21
50	2	165	127	19	8-M20	92	1.6	23
65	2 1/2	190	149	22	8-M20	105	1.6	26
80	3	210	168.5	22	8-M20	127	1.6	29
100	4	254	200	22	8-M20	157	1.6	32
125	5	279	235	22	8-M20	186	1.6	35
150	6	318	270	22	12-M20	216	1.6	37
200	8	381	330	25	12-M24	270	1.6	42
250	10	445	387.5	29	16-M27	324	1.6	48
300	12	521	451	32	16-M30	381	1.6	51
350	14	584	514.5	32	20-M30	413	1.6	54
400	16	648	571.5	35	20-M33	470	1.6	58
450	18	711	628.5	35	24-M33	533	1.6	61
500	20	775	686	35	24-M33	584	1.6	64
600	24	914	813	41	24-M39	692	1.6	70
700	28	1035	940	45	28-M42	800	1.6	86
800	32	1149	1054	52	28-M48	914	1.6	99

CLASS400 RF

DN	NPS	D	k	L	螺栓n-Th	d	f	C
25	1	124	89	19	4-M16	51	6.4	18
40	1 1/2	156	114.5	22	4-M20	73	6.4	23
50	2	165	127	19	8-M16	92	6.4	26
65	2 1/2	190	149	22	8-M20	105	6.4	29
80	3	210	168	22	8-M20	127	6.4	32
100	4	254	200	26	8-M24	157	6.4	35
125	5	279	235	26	8-M24	186	6.4	38.5
150	6	318	270	26	12-M24	216	6.4	41.5
200	8	381	330	29	12-M27	270	6.4	48
250	10	445	387.5	32	16-M30	324	6.4	54
300	12	521	451	35	16-M30	381	6.4	57.5
350	14	584	514.5	35	20-M33	413	6.4	60.5
400	16	648	571.5	39	20-M36	470	6.4	63.5
450	18	711	628.5	39	24-M36	533	6.4	67
500	20	775	686	42	24-M39	584	6.4	70
600	24	914	813	48	24-M45	692	6.4	76.5
700	28	1035	940	50	28-M48	800	6.4	95
800	32	1149	1054	54	28-M52	914	6.4	108

INTEGRAL STEEL PIPE FLANGE ASME/ANSI B16.5A-1992 B 16.47-1996

整体钢制管法兰ASME/ANSI B16.5A-1992 B 16.47-1996

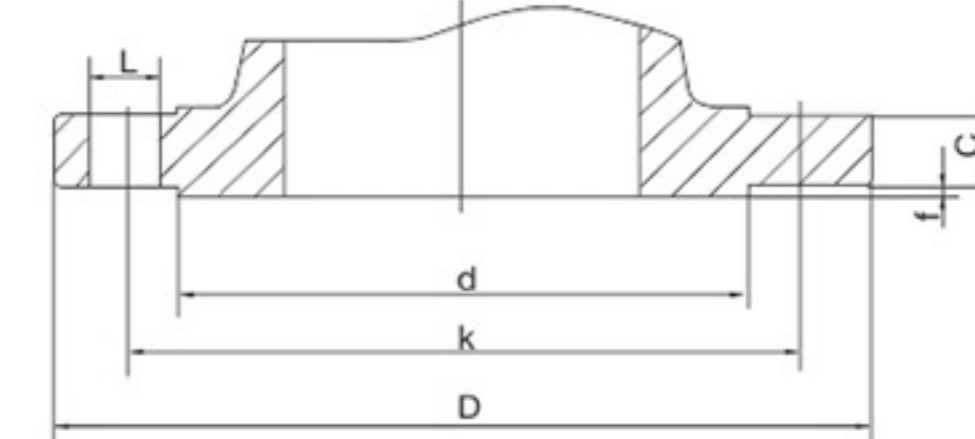

CLASS600 RF

DN	NPS	D	k	L	螺栓n-Th	d	f	C
25	1	124	89	19	4-M16	51	6.4	18
40	1 1/2	156	114.5	22	4-M20	73	6.4	23
50	2	165	127	19	8-M16	92	6.4	26
65	2 1/2	190	149	22	8-M20	105	6.4	29
80	3	210	168	22	8-M20	127	6.4	32
100	4	273	216	25	8-M24	157	6.4	38
125	5	330	266.5	29	8-M27	186	6.4	45
150	6	356	292	29	12-M27	216	6.4	48
200	8	419	349	32	12-M30	270	6.4	56
250	10	508	432	35	16-M33	324	6.4	64
300	12	559	489	35	20-M33	381	6.4	67
350	14	603	527	38	20-M36	413	6.4	70
400	16	686	603	41	20-M39	470	6.4	77
450	18	743	654	44	20-M42	533	6.4	83
500	20	813	724	44	24-M42	584	6.4	89
600	24	940	838	52	24-M48	692	6.4	102
700	28	1073	965.2	54	28-M48	800	6.4	111
800	32	1194	1079.5	60	28-M56	914	6.4	117

CLASS900 RF

DN	NPS	D	k	L	螺栓n-Th	d	f	C
25	1	149	101.6	26	4-M24	51	6.4	29
32	1 1/2	159	111.1	26	4-M24	64	6.4	29
40	2	178	123.8	29	4-M27	73	6.4	32
50	2 1/2	216	165.1	26	8-M24	92	6.4	38.5
65	3	244	190.5	29	8-M27	105	6.4	41.5
80	4	241	190.5	26	8-M24	127	6.4	38.5
100	5	292	234.9	32	8-M30	157	6.4	44.5
150	6	381	317.5	32	12-M30	216	6.4	56
200	8	470	393.7	39	12-M36	270	6.4	63.5
250	10	545	469.9	39	16-M36	324	6.4	70
300	12	610	533.4	39	20-M36	381	6.4	79.5
350	14	640	558.8	42	20-M39	413	6.4	86
400	16	705	615.9	45	20-M42	470	6.4	89
450	18	787.4	685.8	51	20-M48	533	6.4	102
500	20	857	749.3	54	20-M52	584	6.4	108
600	24	1041.4	901.7	67	20-M64	692	6.4	140

CLASS1500 RF

DN	NPS	D	k	L	螺栓n-Th	d	f	C
25	1	149	101.6	26	4-M24	51	6.4	29
32	1 1/2	159	111.1	26	4-M24	64	6.4	29
40	2	178	123.8	29	4-M27	73	6.4	32
50	2 1/2	216	165.1	26	8-M24	92	6.4	38.5
65	3	244	190.5	29	8-M27	105	6.4	41.5
80	4	267	203.2	32	8-M30	127	6.4	48
100	5	311	241.3	35	8-M33	157	6.4	54
150	6	394	317.5	39	12-M36	216	6.4	83
200	8	483	393.7	45	12-M42	270	6.4	93
250	10	585	482.6	51	12-M48	324	6.4	108
300	12	673	571.5	54	16-M52	381	6.4	124
350	14	750	635	61	16-M56	413	6.4	133.5
400	16	825	704.8	67	16-M64	470	6.4	146.5
450	18	915	774.7	74	16-M72	533	6.4	162
500	20	985	831.8	80	16-M76	584	6.4	178
600	24	1684	990.6	91.9	16-M90	692	6.4	203.5

CAST STEEL FLANGE ACC. TO EN1092

德国铸钢法兰 EN1092

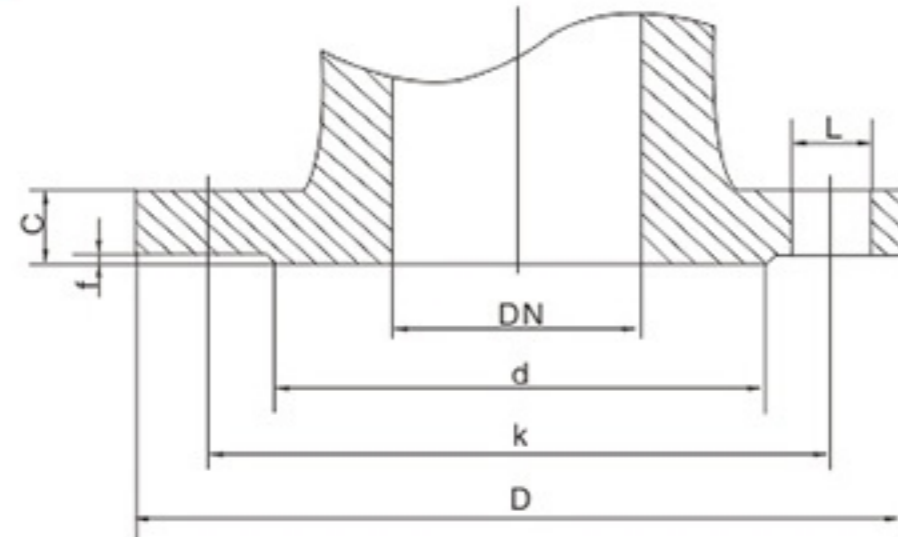

DIN PN1.6MPa RF

DN	D	k	L	螺栓n-Th	d	f	C
15	95	65	14	4-M12	45	2	16
20	105	75	14	4-M12	58	2	18
25	115	85	14	4-M12	68	2	18
32	140	100	18	4-M16	78	2	18
40	150	110	18	4-M16	88	3	18
50	165	125	18	4-M16	102	3	20
65	185	145	18	4-M16	122	3	18
80	200	160	18	8-M16	138	3	20
100	220	180	18	8-M16	158	3	20
125	250	210	18	8-M16	188	3	22
150	285	240	22	8-M20	212	3	22
200	340	295	22	12-M20	268	3	24
250	405	355	26	12-M24	320	3	26
300	460	410	26	12-M24	378	4	28
350	520	470	26	16-M24	438	4	30

DIN PN2.5MPa RF

DN	D	k	L	螺栓n-Th	d	f	C
15	95	65	14	4-M12	45	2	16
20	105	75	14	4-M12	58	2	18
25	115	85	14	4-M12	68	2	18
32	140	100	18	4-M16	78	2	18
40	150	110	18	4-M16	88	3	18
50	165	125	18	4-M16	102	3	20
65	185	145	18	8-M16	122	3	22
80	200	160	18	8-M16	138	3	24
100	235	190	22	8-M20	162	3	24
125	270	220	26	8-M24	188	3	26
150	300	250	26	8-M24	218	3	28
200	360	310	26	12-M24	278	3	30
250	425	370	30	12-M24	335	3	32
300	485	430	30	16-M27	395	4	34
350	555	490	33	16-M30	450	4	38

DIN PN4.0MPa RF

DN	D	k	L	螺栓n-Th	d	f	C
15	95	65	14	4-M12	45	2	16
20	105	75	14	4-M12	58	2	18
25	115	85	14	4-M12	68	2	18
32	140	100	18	4-M16	78	2	18
40	150	110	18	4-M16	88	3	18
50	165	125	18	4-M16	102	3	20
65	185	145	18	8-M16	122	3	22
80	200	160	18	8-M16	138	3	24
100	235	190	22	8-M20	162	3	24
125	270	220	26	8-M24	188	3	26
150	300	250	26	8-M24	218	3	28
200	375	320	30	12-M27	285	3	34
250	450	385	33	12-M30	345	3	38
300	515	450	33	16-M30	410	4	42
350	580	510	36	16-M30	465	4	46

BUTT WELDED ENDS ASME B16.25

对接焊端 ASME B16.25

公称管径 Nominal pipe size	管号 Schedule Number or Wall	焊端外径 Outside Diameter		公称内径 Nominal Inside Diameter		机加内径 Machined Inside Diameter		管子壁厚 Nominal Wall Thickness	
		inch	mm	inch	mm	inch	mm	inch	mm
2-1/2	40	2.88	73.0	2.469	62.6	2.479	62.97	0.203	5.0
	80			2.323	59.0	2.351	59.72	0.276	7.1
	160			2.125	54.0	2.178	55.32	0.375	10
	XXS			1.771	45.0	1.868	47.45	0.552	14.0
3	40	3.50	88.9	3.068	77.9	3.081	78.26	0.126	5.6
	80			2.900	73.7	2.934	74.52	0.300	8
	160			2.624	66.7	2.692	68.38	0.438	11
	XXS			2.300	58.5	2.409	61.19	0.600	15
3-1/2	40	4.00	101.6	3.548	90.2	3.564	90.53	0.226	5.6
	80			3.364	85.4	3.402	86.41	0.318	8
4	40	4.50	114.3	4.026	102.3	4.044	102.72	0.237	5.9
	80			3.826	97.1	3.869	98.27	0.337	8.8
	120			3.624	92.1	3.692	93.78	0.438	11
	160			3.438	87.3	3.530	89.66	0.531	14.2
5	40	5.56	139.7	5.047	128.1	5.070	128.78	0.258	6.3
	80			4.813	122.3	4.866	126.60	0.375	10
	120			4.563	115.9	4.647	118.03	0.500	12.5
	160			4.313	109.5	4.428	112.47	0.625	16
6	40	6.62	168.3	6.065	154.1	6.094	154.79	0.280	7.1
	80			5.761	146.3	5.828	148.03	0.432	11.0
	120			5.501	139.7	5.600	142.24	0.562	14.2
	160			5.187	131.7	5.326	135.28	0.719	17.5
8	40	8.62	219.1	8.981	202.7	9.020	203.71	0.322	8
	60			7.813	198.5	7.873	199.97	0.406	10
	80			7.625	193.7	7.709	195.81	0.500	12.5
	100			7.437	188.9	7.544	191.62	0.594	16
10	120	8.62	219.1	7.187	182.5	7.326	186.08	0.719	17.5
	140			7.001	177.9	7.163	181.94	0.812	20
	160			6.875	174.7	7.053	179.15	0.875	22.2
	XXS			6.813	173.1	6.998	177.75	0.906	22.5

BUTT WELDED ENDS ASME B16.25

对接焊端 ASME B16.25

公称管径 Nominal pipe size	管号 Schedule Number or Wall	焊端外径 Outside Diameter		公称内径 Nominal Inside Diameter		机加内径 Machined Inside Diameter		管子壁厚 Nominal Wall Thickness	
		inch	mm	inch	mm	inch	mm	inch	mm
10	40	10.75	273	10.020	254.4	10.070	255.78	0.365	8.8
	60			9.750	247.6	9.834	249.78	0.500	12.5
	80			9.562	242.8	9.670	245.62	0.594	16
	100			9.312	236.4	9.451	240.06	0.719	17.5
	120			9.062	230.2	9.232	234.49	0.844	22.2
	140			8.750	222.2	8.959	227.56	1.000	25
	160			8.500	215.8	8.740	222.00	1.125	28
12	STD	12.75	323.9	12.00	304.8	12.053	306.15	0.375	9.5
	40			11.938	303.2	11.999	304.77	0.406	10
	XS			11.750	298.4	11.834	300.58	0.500	12.7
	60			11.626	295.2	11.725	297.82	0.562	14.2
	80			11.374	288.8	11.505	282.23	0.688	17.5
	100			11.062	281.0	11.232	285.29	0.844	22.2
	120			10.750	273.0	10.959	278.36	1.000	25
	140			10.500	266.6	10.740	272.80	1.125	28
	160			10.126	257.2	10.413	264.49	1.312	32
14	STD	14.00	355.6	13.250	336.6	13.303	337.90	0.375	9.5
	40			13.124	333.4	13.192	355.08	0.438	11
	XS			13.000	330.2	13.084	332.33	0.500	12.7
	60			12.812	325.4	12.920	328.17	0.594	16
	80			12.500	317.6	12.646	321.21	0.750	20
	100			12.124	308.0	12.318	312.88	0.938	25.8
	120			11.812	300.0	12.044	305.92	1.094	28
	140			11.500	292.0	11.771	298.98	1.250	32
	160			11.188	284.2	11.498	292.05	1.406	36

